

Information to Help You Prepare for Your Truth in Housing Evaluation

Most houses in St. Paul will have some items marked “B” for “Below” and “H” for “Hazardous” on the Truth in Housing evaluation.

The only item the City of St. Paul requires to be fixed are smoke detectors.

Every home must have one “hardwired” (wired into the house wiring) smoke detector. The smoke detector should be on the level with the most bedrooms. If both floors have the same number of bedrooms, put the smoke detector on the highest floor. (Duplexes are not required to have a hardwired smoke detector under the St. Paul Truth in Housing guidelines.)

When I arrive, I’ll need about 1¼ hours to do the following:

- Look at the basement, every room, and attic.
- Test the hot water heater and furnace.
- Test plumbing fixtures and electrical outlets.
- Test the smoke detectors.
- Look at the outside of the house and inside the garage.
- Print out your report.

The next page is a list of common “H” items. There are other possible items not on this list. For more information, go to the Truth in Housing website shown below.

This partial list is provided by Apple Home Inspections Inc. as a courtesy only. For more information, go to the city website at www.ci.stpaul.mn.us or call Apple at 651-644-3999.



Common Truth in Housing Hazardous (H) Items (These apply to both house and garage)

Smoke and CO Detectors

- No hardwired smoke detector near main sleeping area
- No carbon monoxide (CO) detector within 10 feet of every bedroom
- Detectors improperly located
- Detectors not working

Floor Drain

- Cleanout plug is missing or loose

Basement Plumbing

- Water utility is off to whole house
- Any plumbing fixture without water running (causes trap water to evaporate and sewer gas to come in)
- Drain pipe leaking
- Repairs to drain pipes using tape, caulk, rags, etc.
- Abandoned pipe openings not properly capped
- Well water and city water supplies interconnected (if well exists)

Gas Piping

- Broken shutoff valve
- Water valve used as gas valve
- Abandoned gas piping not properly capped

Water Heater

- Back spillage of gases at draft hood (on top of water heater)
- Broken or missing knobs or controls
- Leaking tank
- Scorch marks
- No relief valve
- Improperly located relief valve
- Relief valve appears inoperative

- Relief pipe is plugged or capped
- Vent pipe missing, has holes or gaps
- Vent pipe not sealed tightly to chimney

Electrical System

- No jumper wire around water meter
- Jumper wire loose or not clamped on both sides of the water meter
- Breakers or fuses missing
- Electrical panel cover missing
- Deadfront (inside cover) missing
- Improper add-on fuse boxes or panels

Wiring, Outlets, Switches

- No GFCI outlet in the bathroom
- GFCI test button doesn't trip off the power to the outlet
- 3-prong outlet not grounded
- Any open electrical box of any kind
- Missing knockout plugs (open holes) in any electrical panel or box
- Missing or broken outlet cover
- Missing or broken switch cover
- Damaged outlet or switch
- Broken bulb in light socket
- Extension cords used in place of permanent wiring, or run through walls, floors, cabinets
- Wires spliced outside of an electrical box
- Wires ending outside of an electrical box

Heating System

- Excessive scorching of the cover panel

- Missing or damaged controls
- No backflow preventer on water supply line to boiler
- No pressure relief valve on boiler
- Pressure relief pipe on boiler is plugged or capped

Heating System Vent Pipe

- Vent pipe has holes or gaps
- Vent pipe not sealed tightly to chimney
- Improper clearance to combustibles (generally no closer than 6" to wood, walls, etc. is allowed)
- Back spillage of gases at vent hood

Kitchen and Bathroom Plumbing

- Toilet fill valve (in toilet tank) lacks at least a 1 inch clearance above the overflow tube
- Any plumbing fixture without water running (causes trap water to evaporate and sewer gas to come in)
- Spout below the spill line of the sink or tub
- Drain pipe leaking
- Repairs to drain pipes using tape, caulk, rags, etc.
- Abandoned pipe openings not properly capped

Miscellaneous

- Exposed rigid foam insulation (must be covered with sheetrock or wood unless it is foil-faced)
- Broken glass with jagged edges
- Fireplace or woodstove sharing a chimney flue with a gas appliance

***This partial list is provided by Apple Home Inspections Inc.
as a courtesy only. For more information, go to the
city website at <http://www.ci.stpaul.mn.us>
or call Apple at 651-644-3999.***



Common Repairs

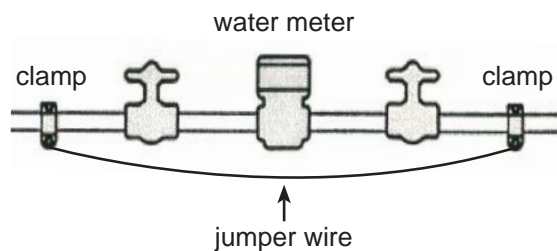

A copper jumper wire must be clamped on both sides of the water meter as shown. This keeps the house electrical system grounded even if the water meter is removed. **The jumper wire is not the plastic-covered wire that is used to read the water meter.** Use a piece of #6 gauge copper wire if your electrical service is 60, 100, or 150 amp. Use #4 gauge copper wire for 200 amp services.

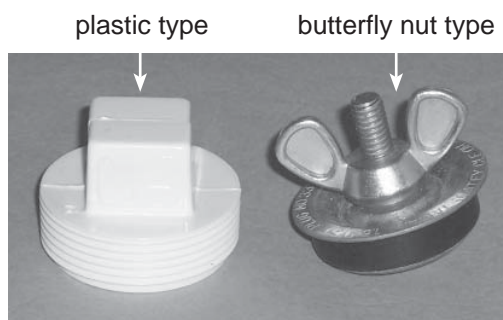
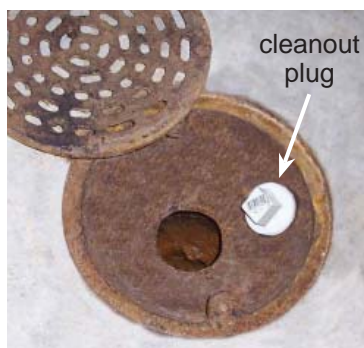

Cleanout plug in side of floor drain. **The cleanout plug must be tight-fitting.** If there are still good threads in the hole, you can use a new plastic plug as shown. If the threads are rusted away, use a plug with a butterfly nut as shown.

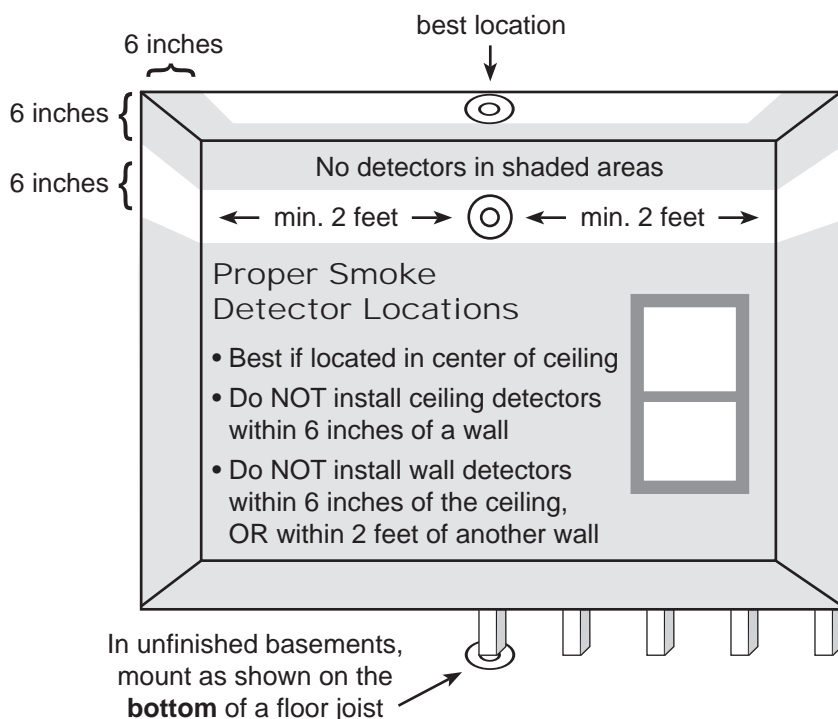

These are GFCI outlets. They should trip off (no power) when the test button is pushed. If they don't, they are either wired wrong or the outlet is defective.



How to adjust a toilet fill valve

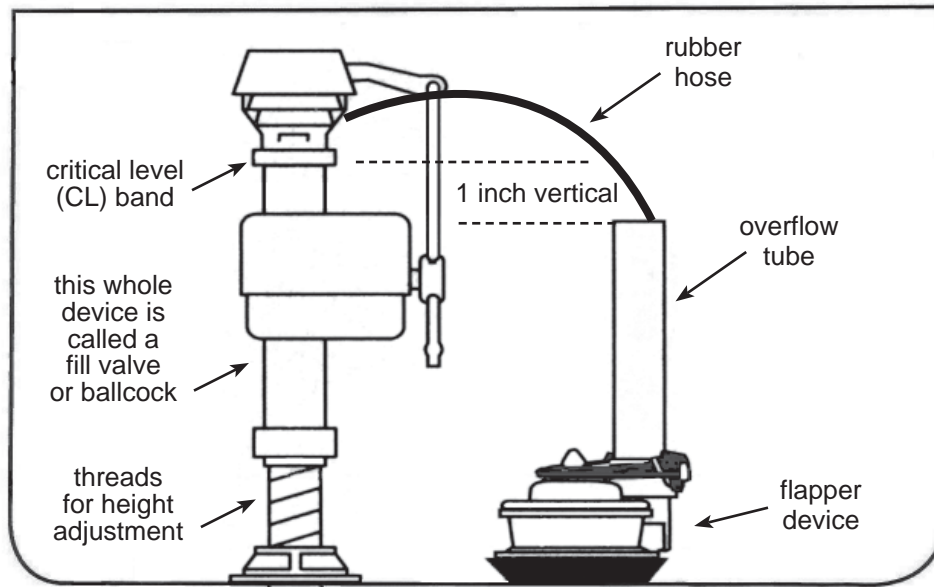

Most people have trouble understanding this repair. As a courtesy, I've prepared these step-by-step instructions. It may be necessary to replace the parts in the tank, depending on the toilet.

The goal is to have a 1 inch vertical space between the "critical level" (as shown) and the top of the overflow tube. It prevents the water in the tank from accidentally being siphoned back into the house drinking water.

- 1) You may be able to simply cut off the top of the overflow tube to get the 1 inch space. However, cutting off the overflow tube permanently lowers the water level in the tank. This will only work if the tank is still full enough for a complete flush.
- 2) Disconnect the rubber hose from the fill valve.
- 3) Turn the whole fill valve around like a screw (threads are at bottom, as shown). One direction will raise the whole unit, the other direction will lower it. You want to raise it.
- 4) You can usually raise the fill valve higher than the top of the tank, because the underside of the lid has space in it.

Here's another type of toilet. There is usually a way to adjust the height of the fill valve on this type of toilet also.

